

SUBDIVISION OF LAND

Town of Canadice Design Criteria and Constriction Specifications for Land Development Appendix A1 [Adopted 3-11-2002 by Res. No. 26-2002]

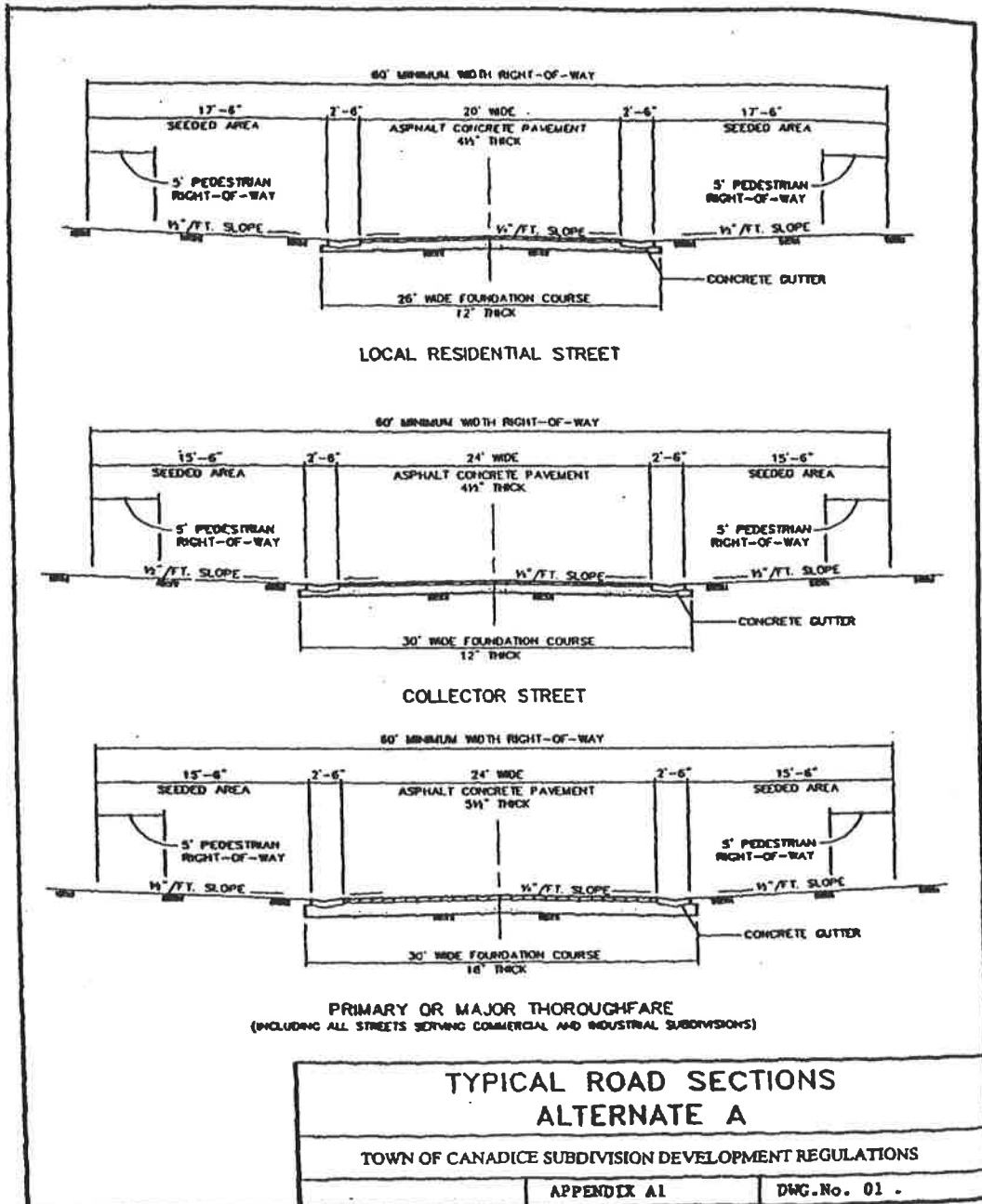

SUBDIVISION OF LAND

Town of Canadice
Design Criteria and Construction
Specifications for Land Development
Appendix A2
[Adopted 3-11-2002 by Res. No. 26-2002]

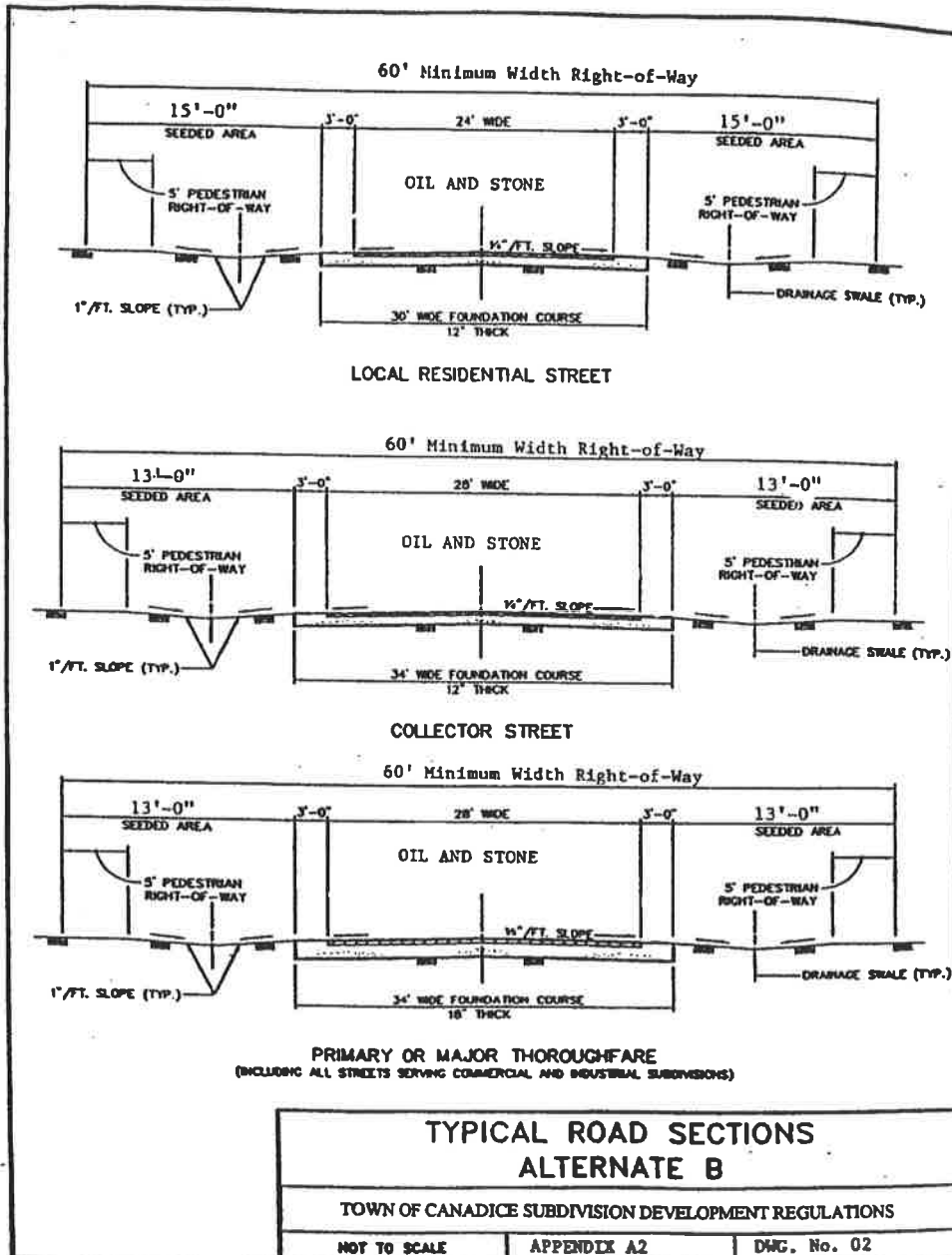

SUBDIVISION OF LAND

Town of Canadice
Design Criteria and Construction
Specifications for Land Development
Appendix B
[Adopted 3-11-2002 by Res. No. 26-2002]

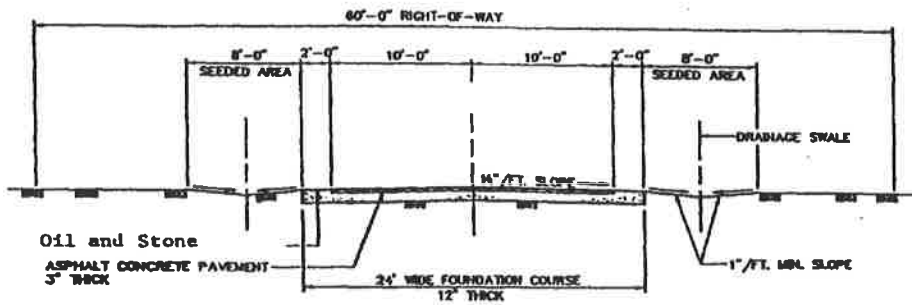

TYPICAL SECTION - ASPHALT CONCRETE PAVEMENT

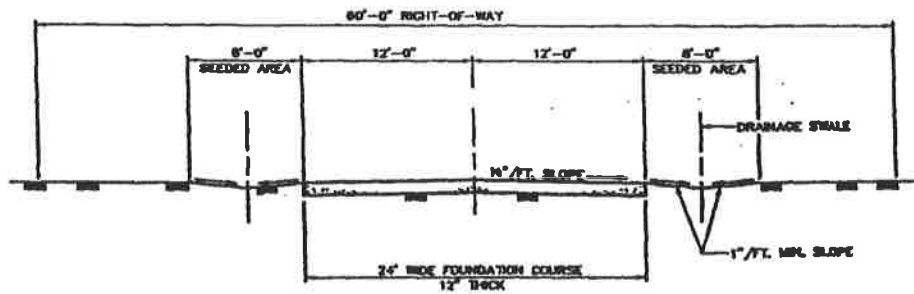

TYPICAL SECTION - OIL AND STONE

PRIVATE ROAD DETAILS (5 LOTS OR MORE)

TOWN OF CANADICE SUBDIVISION DEVELOPMENT REGULATIONS

APPENDIX B

DWG.No. 03

SUBDIVISION OF LAND

Town of Canadice
Design Criteria and Construction
Specifications for Land Development
Appendix C
[Adopted 3-11-2002 by Res. No. 26-2002]

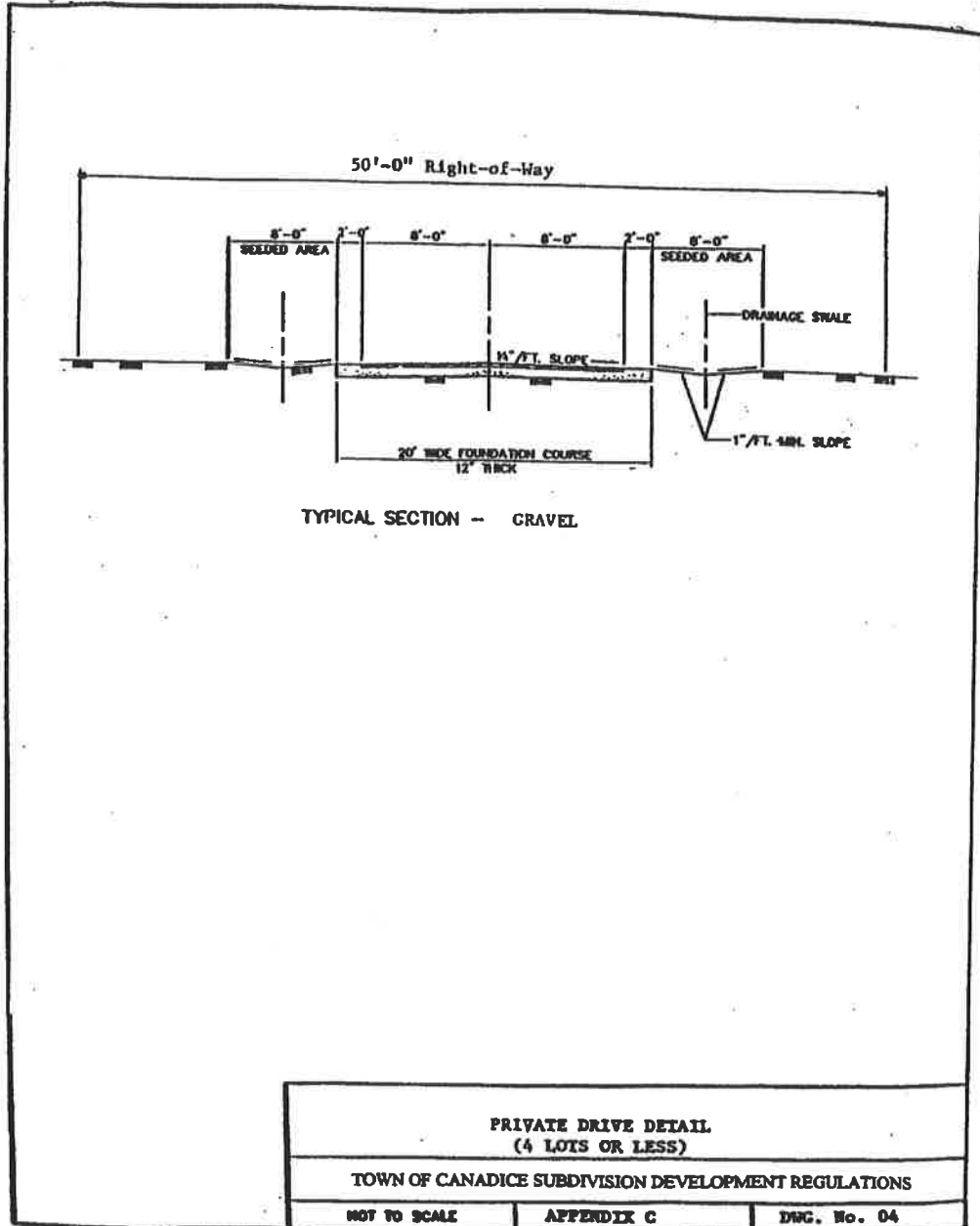

SUBDIVISION OF LAND

Town of Canadice
Design Criteria and Construction
Specifications for Land Development
Appendix C1
[Adopted 3-11-2002 by Res. No. 26-2002]

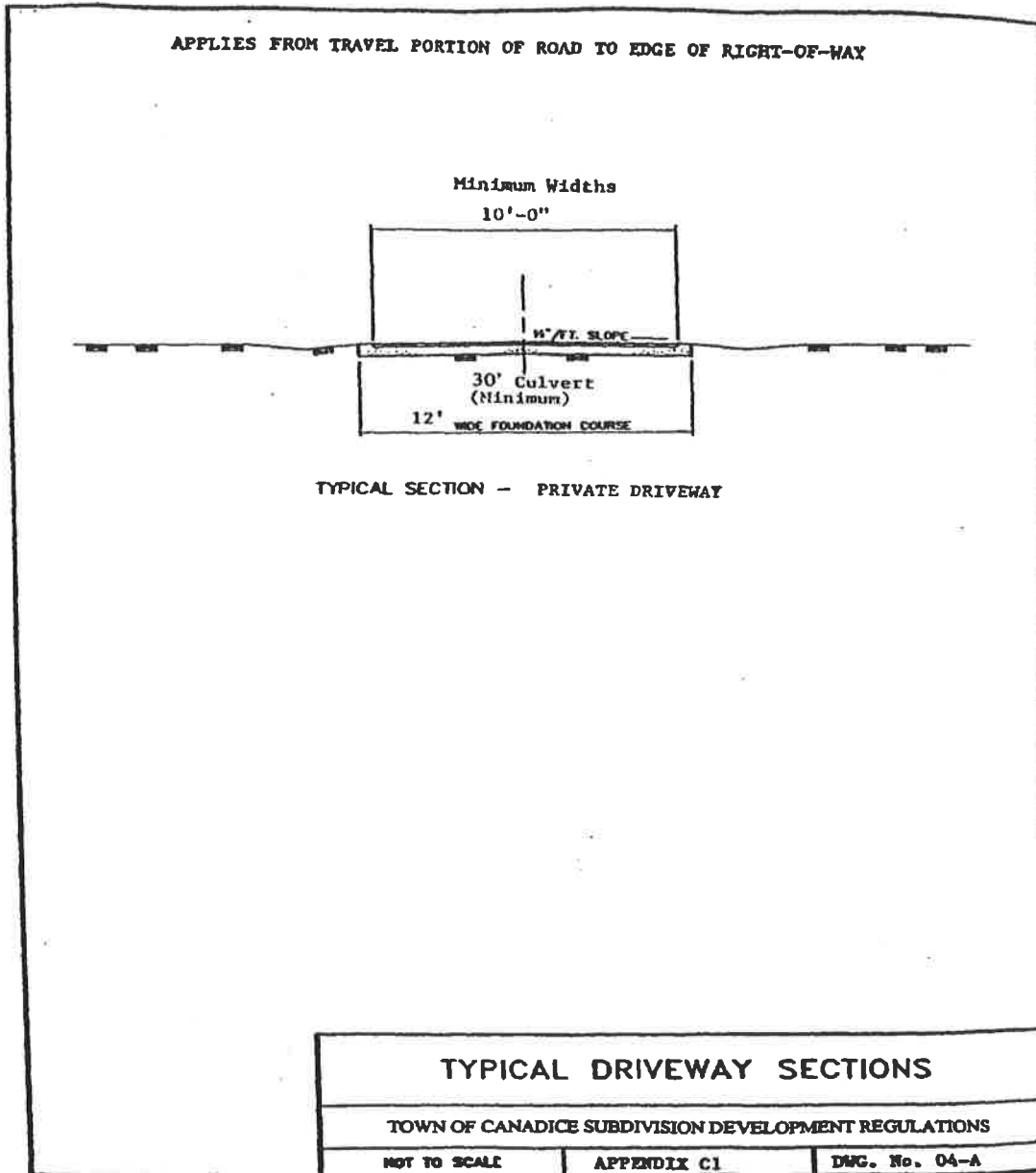

SUBDIVISION OF LAND

**Town of Canadice
Design Criteria and Construction
Specifications for Land Development
Appendix D
[Adopted 3-11-2002 by Res. No. 26-2002]**

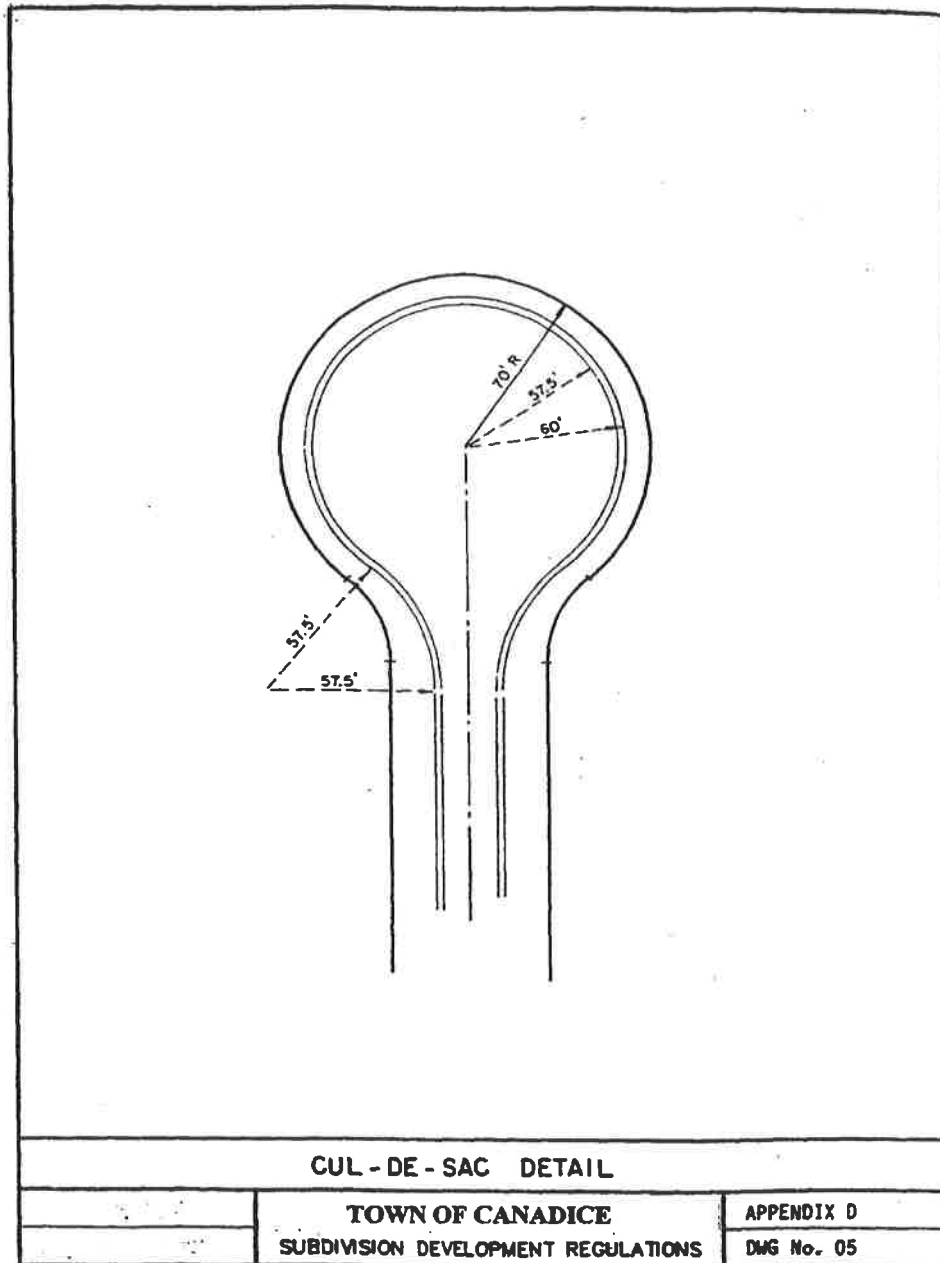

SUBDIVISION OF LAND

Town of Canadice Design Criteria and Construction Specifications for Land Development Appendix E [Adopted 3-11-2002 by Res. No. 26-2002]

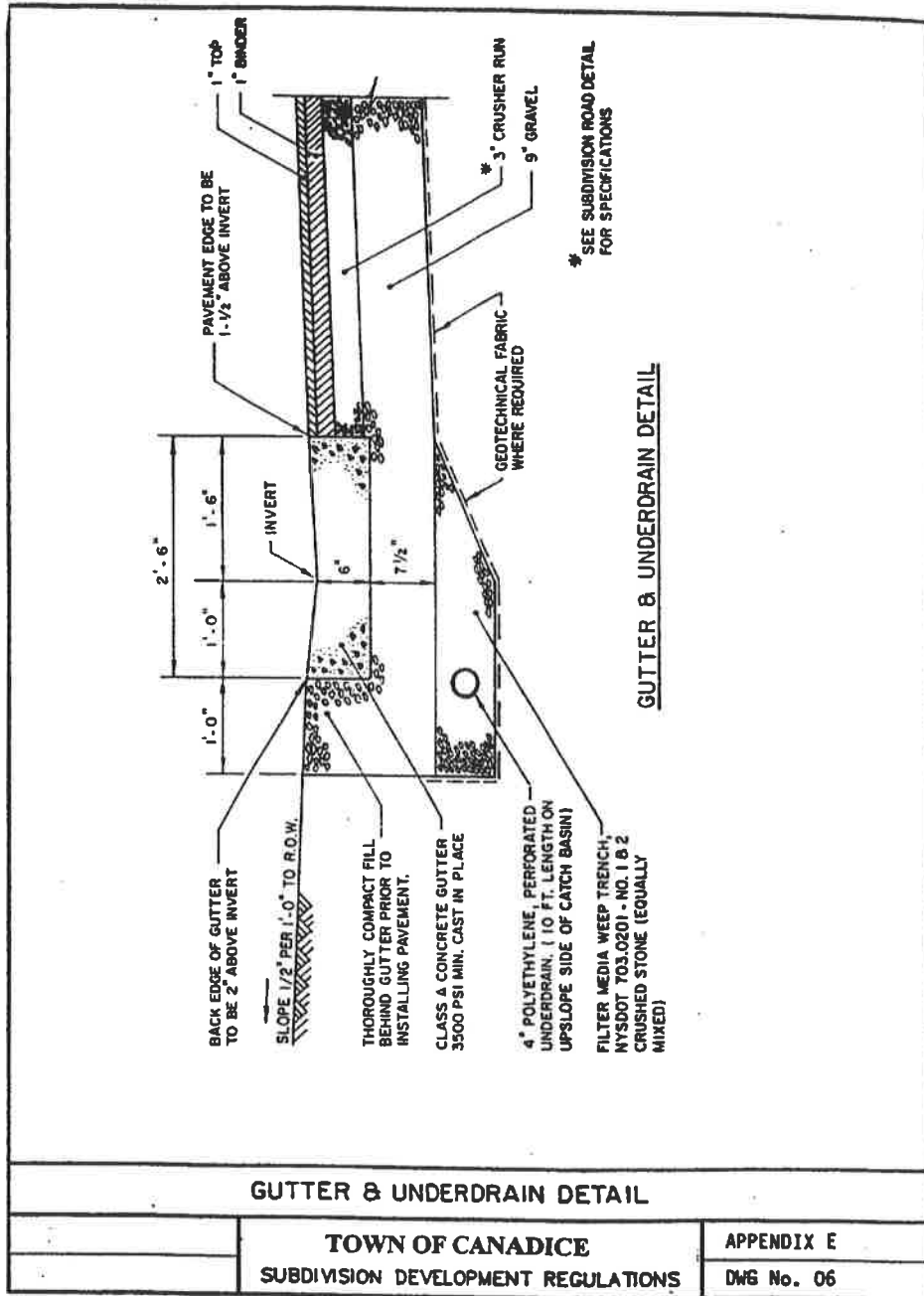

SUBDIVISION OF LAND

Town of Canadice Design Criteria and Construction Specifications for Land Development Appendix F [Adopted 3-11-2002 by Res. No. 26-2002]

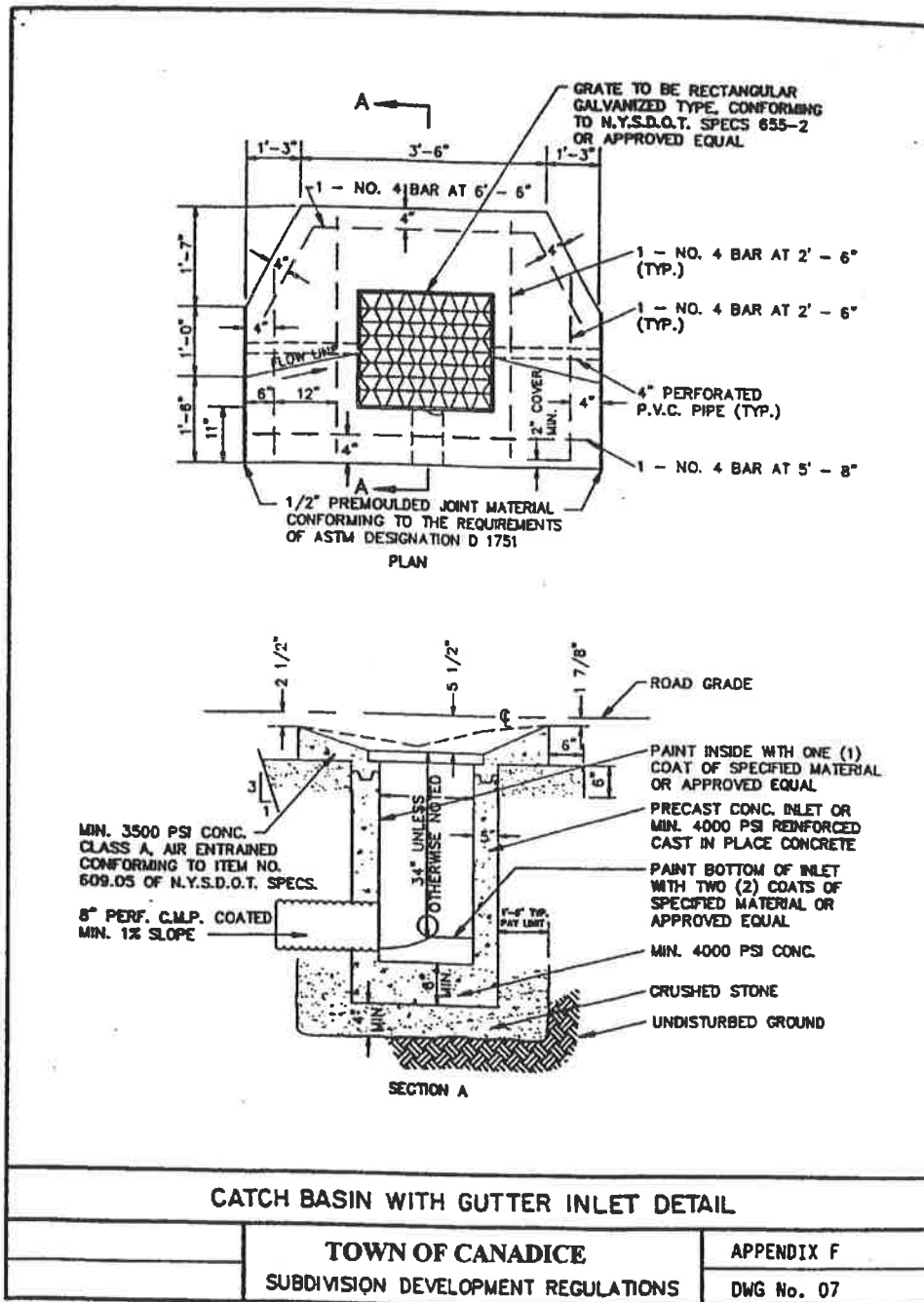

SUBDIVISION OF LAND

Town of Canadice Design Criteria and Construction Specifications for Land Development Appendix G

[Adopted 3-11-2002 by Res. No. 26-2002]

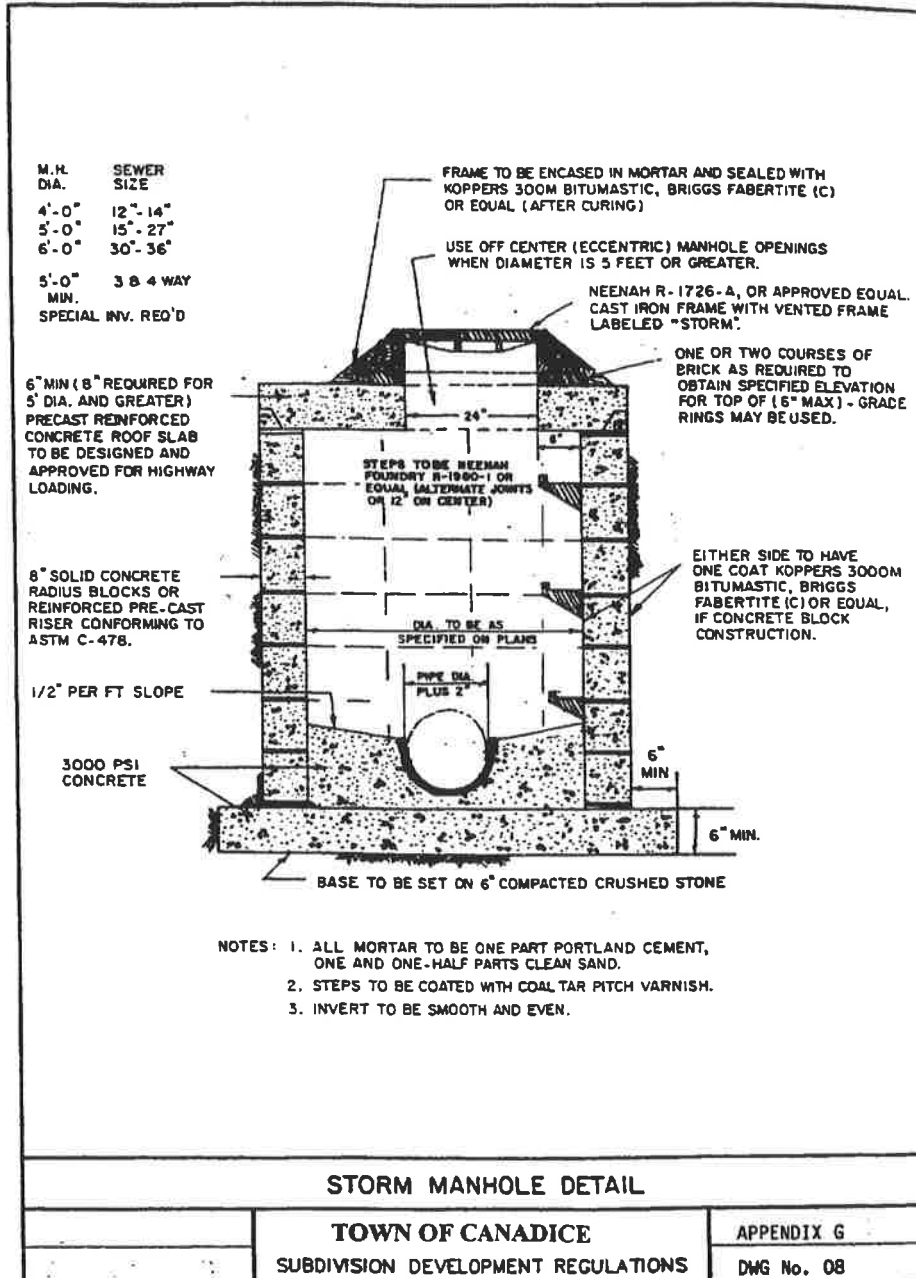

SUBDIVISION OF LAND

Town of Canadice
Design Criteria and Construction
Specifications for Land Development
Appendix H
[Adopted 3-11-2002 by Res. No. 26-2002]

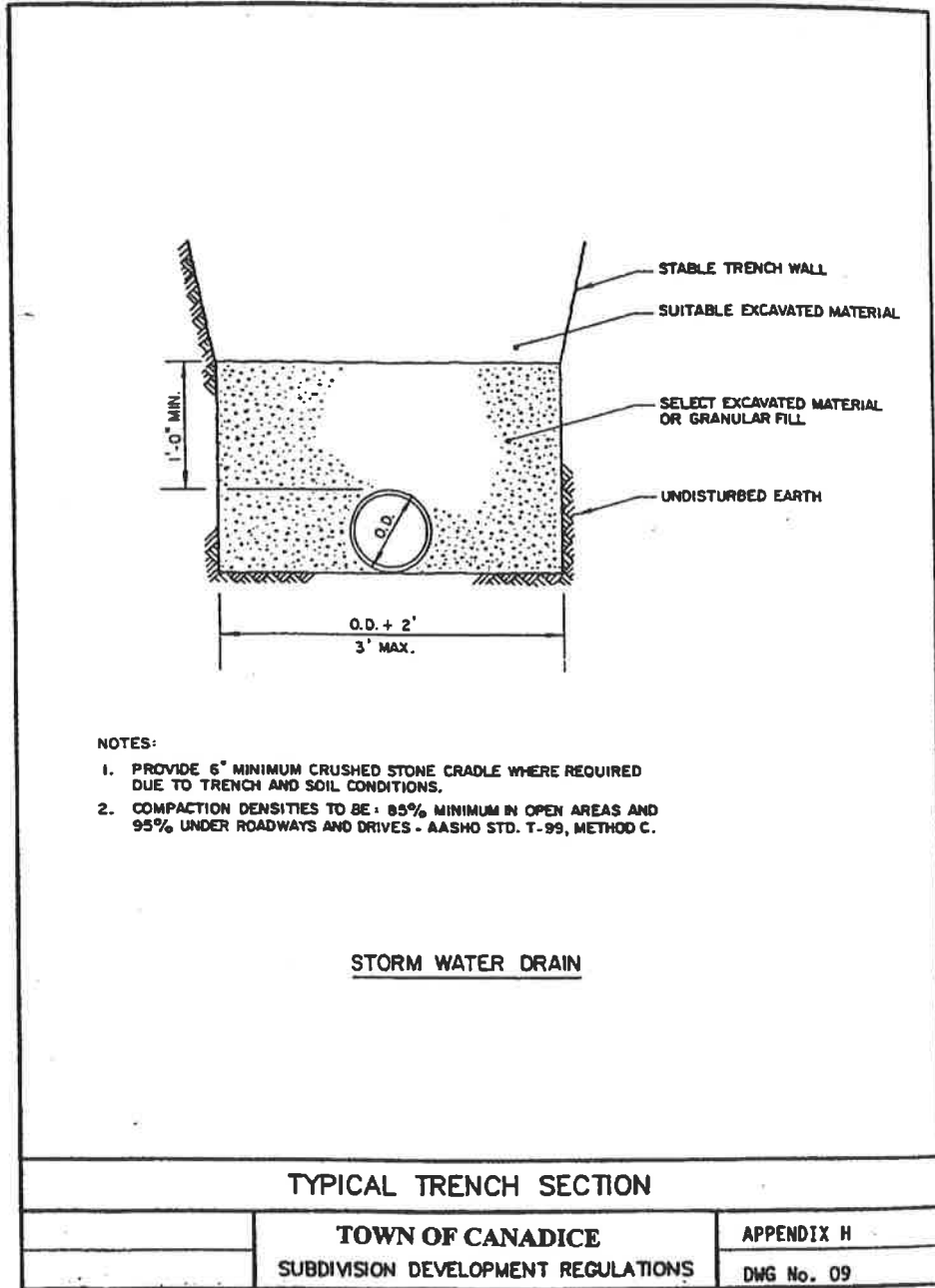

SUBDIVISION OF LAND

Town of Canadice
Design Criteria and Construction
Specifications for Land Development
Appendix I
[Adopted 3-11-2002 by Res. No. 26-2002]

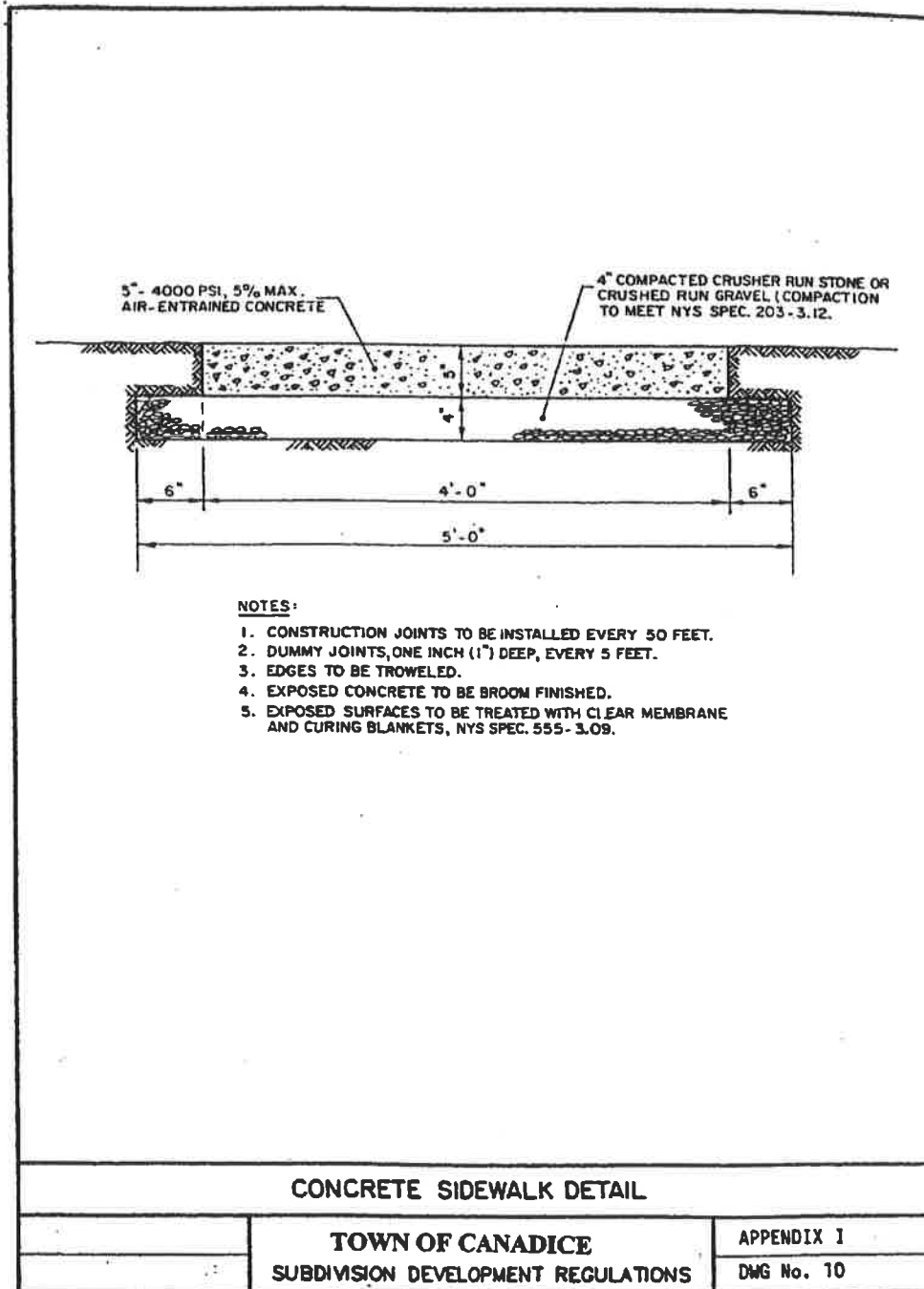

SUBDIVISION OF LAND

Town of Canadice
Design Criteria and Construction
Specifications for Land Development
Appendix J
[Adopted 3-11-2002 by Res. No. 26-2002]

